

Auto Ref-Keratometer/Refractometer

# ACCUREF K-900/R-800

SPECIFICATIONS		K-900	R-800	
Refractive measurement range (Ref measurement)	Sphere (S)	Measurement range	-30D~+22D (VD=12) -22D~+30D (VD=0)	-30D~+22D (VD=12) -22D~+30D (VD=0)
		Unit	0.12D, 0.25D (Switching)	0.12D, 0.25D (Switching)
	Cylinder (C)	Measurement range	0D~±10D (VD=0)	0D~±10D (VD=0)
		Unit	0.12D, 0.25D (Switching)	0.12D, 0.25D (Switching)
		symbol	-, +, ± (Switching)	-, +, ± (Switching)
	Axis (A)	Measurement range	0°~180°	0°~180°
Unit	1°	1°		
Vertex distance		0, 10, 12, 13.5, 15mm	0, 10, 12, 13.5, 15mm	
Minimum pupil diameter measurable		φ2.0mm	φ2.0mm	
Corneal curvature radius measurement	Corneal curvature radius	Measurement range	5.0mm~10.0mm	—
		Unit	0.01mm	—
	Corneal refractivity	Measurement range	33.75D~67.5D (where corneal refractive index n=1.3375)	—
		Unit	0.12D, 0.25D (Switching)	—
	Degree of corneal astigmatism	Measurement range	0D~±10D	—
		Unit	0.12D, 0.25D (Switching)	—
		symbol	mm, -D, +D (Switching)	—
Axis angle	Measurement range	0°~180°	—	
Unit	1°	—		
PD measurement	Measurement range	85mm(Near PD output)	85mm(Near PD output)	
Unit	1mm	1mm	1mm	
Pupil diameter measurement	Measurement range	φ2.0mm~φ8.5mm	φ2.0mm~φ8.5mm	
	Unit	0.1mm	0.1mm	
Measurement time	Refractive measurement range	Approx. 0.07sec.	Approx. 0.07sec.	
	Corneal curvature radius measurement	Approx. 0.07sec.	—	
Fog control	Fogging for each measurement (Auto)	—	—	
	Fogging is provided at the first measurement followed by continuous measurement (Auto-Quick)	—	—	

### K-900/R-800 Standard Accessories

- Operation Manual
- Power cord
- Printer paper
- Fuse
- Dust cover
- Model eye
- Chin rest paper
- Chin rest paper pin

### MECHANICAL SPECIFICATIONS

Size	(W) 240mm (D) 422mm (H) 430mm
Movement range of the measurement unit	Forward/backward ±22mm Horizontal direction ±43mm Vertical direction ±17mm
Movement range of the chin rest	vertical ±30mm
Movement range of LCD	+30°swivel (left only), +40°tilt
Weight	approx. 13kg

※ Common to K-900/R-800

### ELECTRICAL SPECIFICATIONS

Built-in monitor body	5.7 inch color LCD monitor
Printer	thermal line printer (paper width 58mm)
Power voltage/frequency	AC100V-240V, 50/60Hz
Power consumption	60VA
Power saving function	OFF, 3, 5, 10min. (selectable)

※ Common to K-900/R-800

### External diagram (to scale) and Part Identification

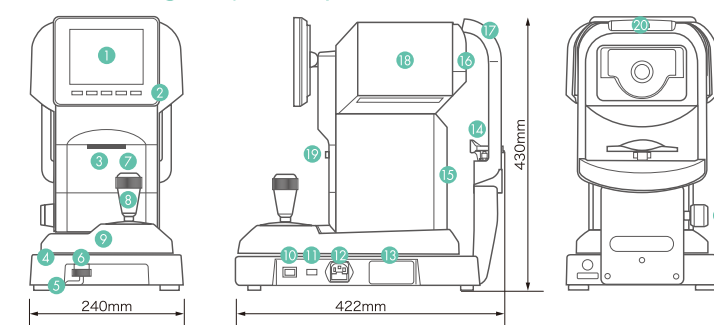

- |                               |                                   |
|-------------------------------|-----------------------------------|
| ① LCD monitor                 | ⑪ RS-232C connector               |
| ② Touch sensor panel          | ⑫ Power plug connector            |
| ③ Printer cover               | ⑬ Rating plate                    |
| ④ Base                        | ⑭ Chin rest                       |
| ⑤ Rubber feet                 | ⑮ Body cover                      |
| ⑥ Main unit sliding lock knob | ⑯ Face panel                      |
| ⑦ Measurement start switch    | ⑰ Head rest                       |
| ⑧ Joystick                    | ⑱ Head cover                      |
| ⑨ Sliding base cover          | ⑲ Printer cover open/close button |
| ⑩ Power switch                | ⑳ Rubber head rest                |
|                               | ㉑ Chin rest knob                  |

Design and specifications are subject to change without notice.

Manufacturer

**Rexxam**  
Rexxam Co.,Ltd.

Kagawa factory  
958, Ikeuchi, Konan-cho,  
Takamatsu, Kagawa 761-1494, Japan

Contact

MEC Sales Division  
2-8-4, Kandatsukasa-machi, Chiyoda-ku  
Tokyo, 101-0048, Japan  
TEL 81-3-3256-7701 FAX 81-3-3256-7702  
E-mail: eye@rexam.co.jp  
URL: http://www.rexxam.co.jp  
URL: http://www.shin-nippon.jp



Distributed by

**SHIN-NIPPON**  
by **Rexxam**



Cool design & User friendly!  
This is new "SHIN-NIPPON" standard.

Auto Ref-Keratometer/Refractometer

# ACCUREF

## K-900/R-800

# Introducing our new Auto Ref-Keratometer & Auto Refractometer!!

In the pursuit of quality and ergonomics, the highest level of perfection and beauty has been achieved.

## Slim, Compact & Stylish Design

A new flat screen monitor with a beautiful graphics display and excellent visibility. Sophistication contained within a simple and compact body design. In the pursuit of ergonomics, minute attention to detail has been paid to materials, texture and finish in order to ensure superb operability. At last, a solidly reliable optical unit. Focus on high quality for each and every component has resulted in the creation of the Auto Ref-Keratometer that will set the standard for the new generation.



ACCUREF K-900

### New Generation DESIGN & STYLE

Exquisite detail and quality. Sophisticated shape combined with soft curves and the attractive color with high quality two-tone metallic and pearlescent paintwork which complements any interior and appeals atmosphere of trust to the customer.

### New Joystick



The completely redesigned joystick with the shape and top button allows the operator to control the unit with more precise and instinctive movement.

### Improved side flaps, head rest and chin rest



Side flaps mounted to each side of the measurement window enabling to block out the light realizes high accuracy. The modified shapes of the forehead rest and the chin rest help to minimize stress of the patient.

### Feather-touch sensor button

The feather-touch sensor button used to interface with the screen enables sensitive and accurate operation.



### Newly designed optical unit with further improved accuracy.

The newly designed optical unit allows measurement of the minimum pupil diameter up to 2.0 mm and high-accuracy measurement. Useful function for actual measurement such as display of reliability warning indicator has been added.

When all setting items are enabled

Message Area	
No. 00001	Date & Time 2011 11 22 14:30
IOL Mark	
Reliability Warning Indicator	Photopic Pupil Diameter
Scotopic Pupil Diameter	Ref Value
	Ref Representative Value
Right Eye	
Kerato Value	
Kerato Representative Value	
Left Eye	
Kerato Value	
Kerato Representative Value	
Residual Astigmatism	
Interpupillary Measurement Function	

## Simple & Easy Operation

A swivel function to the left (30°) and a vertical tilt function (40°) have been added to the monitor unit. This swivel function allows measurement while supporting the patient. The operational screen has been also redesigned completely. The well organized color plan/layout of the high-luminance color LCD panel makes the screen display extremely easy to read.

### Newly designed IOL Mode [color focus indicator]

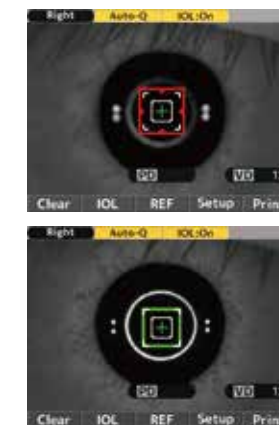

Color changes to green when focus is achieved

A subject with IOL was conventionally difficult to measure but this newly designed IOL mode has made it much easier.

### Scotopic & Photopic Pupil Diameter Measurement

#### Scotopic measurement [S.P.S. function]

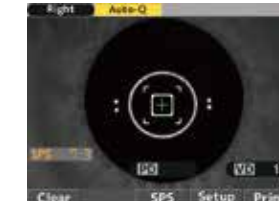

#### Photopic measurement [P.P.S. function]



Both scotopic and photopic measurements are available.

※ S.P.S.: Scotopic Pupil Size  
P.P.S.: Photopic Pupil Size

### Expanded vertical tilt range

The adjustment range of the vertical tilt angle has been expanded to 40°. The unit can comfortably be operated from both seated and standing positions.



Left swivel 30°  
Vertical tilt 40°

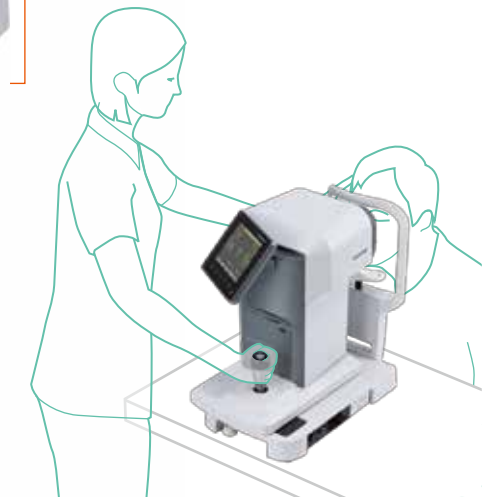

Also introducing our new sister model Auto Refractometer ACCUREF R-800!!

A high-definition model made to the same specifications as K-900, excluding kerato measurement.

ACCUREF R-800

